

YCAS GSi AIR COOLED CHILLERS

REFRIGERANTS R22 AND R134a Cooling Capacities 360kW to 745kW

The YCAS range of chillers are designed for water or water-glycol cooling.

Twin helical semi-hermetic screw compressors, designed for industrial refrigeration applications, are provided to ensure high operational efficiencies and reliable performance.

All units are designed to be located outside on the roof of a building or at ground level.

CONTENTS

- Specification
- Accessories
- Operating Limitations
- Refrigeration Flow Diagram
- Water Pressure Drops
- Selection Guide
- R22 Cooling Capacities
- R134a Cooling Capacities
- Electrical Data
- Electrical Connections
- Physical Data
- Dimensions

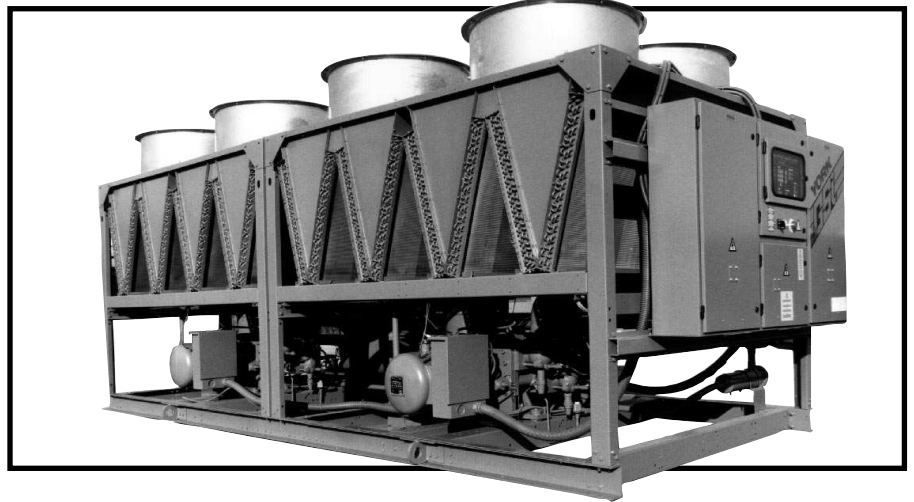

FEATURES	BENEFITS
Manufactured to ISO 9001 EN 29001	High standard of quality control
Refrigerant 134a version	Zero ozone depletion value
Multiple refrigerant circuits	System stand-by security
Minimum base area maximum capacity	Minimum Installation space
Constructed from heavy gauge painted galvanised steel	Durable and weather protected
High efficiency Industrial type semi-hermetic twin helical screw compressor	Energy efficient long life, reliable compressor
Full factory run test	Operating Quality Control
Optional Acoustic Kit	Reduces operating sound levels
Star/ Delta compressor starter	Reduced starting current
Separate power and control compartments with lockable doors and emergency stop device	Operator safety considerations
Power compartment optional door interlocked isolators	Operator safety convenience
Residual current circuit breaker	Operator safety
Microprocessor control with visual display of temperatures, pressures, motor currents, operating hours and number of starts	System data logging and temperature reset capability Fault diagnostics Energy management
Unit remote alarm contacts	Warning notification
Remote water temperature reset	To improve operating efficiency
Building Management System interface	For central data logging and single point full system monitoring and control

R22		R134a	
Size	kW	Size	kW
410	444	335	367
430	467	355	386
480	515	375	406
510	564	395	427
570	610	445	488
620	669	485	524
660	718	505	545
690	744		

Cooling Capacities at 7°C Leaving Chilled Water and 35°C ambient.

SPECIFICATION

GENERAL

The Air Cooled Screw liquid chiller is completely assembled with all interconnecting refrigerant piping and internal wiring, ready for field installation. The unit is pressure-tested, evacuated, and fully charged with Refrigerant R22 or R134a and includes an initial oil charge. After assembly, an operational test is performed with water flowing through the cooler to check that each refrigeration circuit operates correctly. The unit structure is heavy-gauge, galvanised steel, coated with a baked-on enamel. Base rails are of formed double thickness, painted galvanised plate steel.

COMPRESSORS

The Frick, rotary twin-screw compressor has been engineered and constructed to meet the exacting requirements of the industrial refrigeration market. It utilises the latest technology to provide the most reliable and energy-efficient compressor available at all operating conditions. The compressor is driven by an electrical motor via a gear speed control for increased capacity and improved volumetric efficiency. The compressor housing is made of cast iron, precision machined to provide minimal clearance for the rotors. The design working pressure is 16 bar g on the suction side and 30 bar g on the discharge side. The rotors are manufactured from forged steel and use asymmetric profiles.

SPECIFICATION continued

The compressor incorporates a complete anti-friction bearing design for reduced power and increased reliability. Four separate, cylindrical, roller-bearings handle radial loads. Angular-contact ball bearings handle axial loads. Together they maintain accurate rotor positioning at all pressure ratios thereby minimising leakage and maintaining efficiency.

CAPACITY CONTROL

Capacity control is achieved by use of a slide valve which provides fully modulating capacity control from 100% to 15% of chiller full load. The slide valve is actuated by oil pressure controlled by external solenoid valves via the ISN ScrewPak Control Centre.

ACCESSIBLE HERMETIC MOTOR

The compressor motor is refrigerant gas cooled, double squirrel cage, induction type built to York's design specifications, 50Hz motors operate at 2,975 rpm. The motor stator is of epoxy bonded core construction with glass-served windings, and U.L. Class "H" insulation for maximum durability. The terminal boxes are rain-tight. Three parallel-connected, heat-sensing thermistors are an integral part of the motor for reliability protection.

OIL SEPARATOR AND LUBRICATION

The compressor has a closed coupled oil separator with no moving parts to minimize oil carry-over for optimum heat exchanger efficiency. Impingement, direction change and low velocity provide effective separation over a wide range of operating conditions. The main oil reservoir is located in the oil separator. The compressor also has an oil reservoir located at the rotor bearings to provide lubrication during start-up, coast-down and in the event of power failure. During operation, system pressure differential provides proper oil flow without the need of an oil pump. This minimises system energy consumption.

A 500 Watt (230-1-50) immersion oil heater is located in the oil separator reservoir and compressor. It is temperature-actuated to effectively remove refrigerant from the oil during shutdown. Power wiring is provided to the Control Centre. An external, replaceable-cartridge, 3 micron oil filter is provided with manual isolation stop-valves for ease of servicing.

Oil cooling, when required, is provided by liquid injection into the compressor and discharge temperatures for all conditions. The ISN ScrewPak Control Centre provides consistent oil temperature at all times to ensure proper oil viscosity independent of system conditions. This arrangement promotes optimum compressor performance and life.

ECONOMISER

An economiser is included in each refrigerant circuit to enhance the overall system performance. The refrigerant to refrigerant plate type economiser is constructed of acid resistant stainless steel. The compact and pressure resistant heat exchanger package is formed, brazed and the entire material is utilised for heat transfer. The heat exchangers are designed for 31 bar. The temperature limits are -195°C minimum to 185°C maximum.

COOLER

The dual-circuit cooler is the direct-expansion type, with refrigerant in the tubes and chilled liquid flowing through the baffled shell. The design working pressure of the shell is 10 bar g, and 16 bar g for the tube side. The refrigerant side is constructed and tested in accordance with the applicable sections of the ASME Pressure Vessel Code, Section VIII, Division (1). The water side is exempt as per paragraph U-1, (c)(6).

The water baffles are constructed of galvanized steel to resist corrosion. The removable heads allow access to the internally-enhanced, seamless, copper tubes, Vent and drain connections are included.

The cooler is equipped with a heater matt controlled by the ISN panel. The heater provides freeze protection for the cooler down to -29°C ambient. The cooler is covered with 19mm flexible, closed-cell foam insulation.

CONDENSER

Coils - The condenser coils are seamless copper tubes arranged in staggered rows, mechanically expanded into aluminium fins. Integral subcooling is included. The design working pressure of the coil is 30 bar g.

Fans - The condenser fans are glass reinforced-polypropylene, high-efficiency, aerofoil-type fan blades directly driven by independent motors, and positioned for vertical air discharge. The fan guards are constructed of heavy-gauge wire hot dipped galvanised steel. All blades are dynamically and statically balanced for vibration-free operation.

Motors - The fan motors are Totally Enclosed Air-Over, squirrel-cage type. They feature ball bearings that are double-sealed and permanently lubricated. Each motor has Class "F" insulation for maximum durability.

REFRIGERANT CIRCUIT

Independent refrigerant circuits will be included on each unit. All unit piping is ACR copper, with brazed joints. The liquid line includes: a shut-off valve with charging port, sight glass with moisture-indicator, thermal expansion valve, solenoid valve, and filter-drier.

POWER AND CONTROL PANEL

All controls and motor starting equipment necessary for unit operation are factory wired and function tested. Components are mounted on galvanized steel back plates and enclosed in the relevant power or control compartment of the galvanised steel enclosure. On the main control panel door a further door, with perspex viewing window, is located on the exterior of the control compartment door to house the microcomputer keypad and display. All doors are hinged and lockable and include door stays. The control panel is designed to IP55 weather protection and finished in zinc phosphate pre-treated bake enamel coloured Caribbean blue.

The control panel can be located at the opposite end of the unit so that two chillers can be located back-to-back.

EACH POWER COMPARTMENT CONTAINS:

Star/ Delta compressor starting contactors; fan fuses; control interface relays, incoming mains terminal block per compressor as standard or door interlocked fused isolator with padlockable handle, as a further option, common supply incoming mains bus bars are located within the control panel. Control circuit 220/ 230V serving compressor solenoids; compressor heaters; heat exchanger heater mats; compressor and fan contactor coils with residual current circuit breaker.

THE 24 VOLT COMPARTMENT CONTAINS:

Auto/off switch mounted on the door, microprocessor board; power supply board; Opto isolator board. The microcomputer keypad and display mounted under a perspex door on the front of the control compartment incorporates the following features:-

Liquid Crystal Display with light emitting Diode back lighting for outdoor viewing:
Two display lines, twenty characters per line.
Colour coded key pad with sections for:-
DISPLAY of typical information:
Chilled liquid temperature
Ambient temperature
System pressures and temperature (each circuit)
Motor current and percentage (each circuit)
Operating hours and starts (each circuit)
Options listing.

ENTRY section to:

ENTER setpoint changes
CANCEL inputs
ADVANCE DAY
Change AM/PM

SETPOINT updating can be performed to:

Chilled liquid temperature/range
Remote reset temperature range

CLOCK changes for:

Set time
Set daily schedule/holiday for start/stop
Manual override for servicing

PRINT calls up:

Operating data for the systems
History of fault shutdown data of last three faults.

An RS-232 port, in conjunction with this press-to-print button, is provided to permit the capability of hard copy printouts via a separate printer (option).

PROGRAM other functions such as:

Low and high ambient cutouts
Low liquid temperature cutout*
Low suction pressure cutout*
High discharge pressure cutout
Operational setting of condenser fans
Anti-recycle timer (compressor start cycle time)**
Anti-coincident timer (delay compressor starts)

Star Delta starting

* Customer programmable on brine units

** Customer programmable

The Micro Computer Control Centre is capable of displaying the following SI or Imperial data:-

Leaving liquid temperature
Low leaving liquid temperature cutout setting
High and low ambient temperature cutout setting
Outdoor air temperature
Suction pressure cutout setting
Each system suction pressure, discharge pressure,
Oil pressure, motor current and percentage of full load current.
Liquid Temperature Reset via a YORK ISN or building automation system (by others) via:

- a pulse width modulated (PWM) input as standard

Anti-recycle timer status for each compressor

Anti-coincident compressor start timer condition

Oil temperature/safety cutout

Discharge pressure/safety cutout

Discharge temperature/safety cutout

Compressor run status

No cooling load condition

Day, date and time
Out of range message
Daily start/stop times
Holiday status
Automatic or manual lead/lag control
Lead compressor definition
Compressor starts and operating hours each system
Status of evaporator heater and fan operation
Up to 3 fault shut down conditions
Run permissive status
Liquid solenoid valve status
Load and unload timers status
Water pump status

The micro computer keypad and display mounted under a perspex door on the front of the control compartment incorporates the features described in the ISN Control section of this directory.

ACCESSORIES & OPTIONS

THREE WIRE SUPPLY KIT

Additional transformer and wiring to allow control voltage to be internally derived on sites with "3 wire".

LOW AMBIENT KIT

This accessory is factory fitted and includes all necessary components to allow chiller operation down to -18°C condenser intake air.

CONDENSER COIL FIN PROTECTION

Protection against atmospheric pollution.
Options:

- Aluminium fin with baked phenolic coating.
- Copper fins.
- Aluminium fin pre-coated with epoxy and heat cured.

PRESSURE VESSEL CODES

Coolers and oil separators can be supplied in conformance with the following pressure vessel codes:

T.Ue.V. (Germany & Austria)

I.S.P.E.S.L. (Italy)

D.R.I.R.E. (France)

ACOUSTIC KIT - PHASE 1

Factory fitted low noise fans giving reduced unit fan noise with standard air flow.

HIGH STATIC PRESSURE FANS

Factory fitted fans with extra static pressure capability permitting addition of louvres, ductwork, attenuators, etc.

SINGLE POWER CONNECTION PLUS ISOLATORS

Factory fitted option to allow one power connection for the two compressors plus fans and controls with fused door interlocked isolator per power section.

ISOLATORS PLUS SINGLE PHASE CONTROL

Fused door interlocked isolator per power section with terminal block for single phase controls.

CABLE INLET EXTENSION

Extended cable entry gland plate to allow extra spreading area for armoured mains cables.

MICROPANEL ISOLATOR KIT

Field fitted additional PCB allowing volt-free contacts to be located more than 7.5 metres from Chiller panel connections.

EMS OFFSET CARD

Additional PCB to allow remote leaving liquid temperature offset function.

MECHANICAL GAUGE KIT

Factory fitted mechanical dial gauges for discharge, suction and oil pressure indication in addition to transducer pressure display.

VGB 20 COMPLIANCE KIT

Factory fitted additional T.Ue.V. approved high pressure cutout switches.

WIRE PANELS ENCLOSURE

Consists of welded-wire-mesh guards mounted on the exterior of the unit. Prevents unauthorised access, yet provides free air flow.

COOLER FLANGE KIT

Factory fitted victaulic flanges on cooler water connections to ISO R2084-NP10.

COMPANION FLANGE KIT

Victaulic flanges to match cooler flange kit I.S.O. R2084-NP10 supplied loose for field installation by contractor. Includes all necessary nuts, bolts, gaskets etc.

ANTI-VIBRATION MOUNTS

Open spring isolator mounts with 25mm deflection supplied loose for field installation by contractor, with levelling screws and fixing holes.

FLOW SWITCH

Switch with 1 inch IPS thread suitable for 10 bar g DWP and having gold contacts for low voltage/current, to protect unit from loss of water flow. This or an equivalent switch must be furnished with each unit for field installation by contractor.

PRINTER

Hand held printer for obtaining printout of unit operating data and history data.

Table 2

OPERATING LIMITATIONS

		Min.	Max.	Cooler Flow l/s		Water/ Glycol pressure drops kPa	
Leaving Chilled Liquid Temperature °C		4.5	12				
Leaving liquid temperature difference °C		3.3	8				
Model	R22 Unit Size	R134a Unit Size		MIN.	MAX.	MIN.	MAX.
YCAS	410, 430, 480	335, 355, 375, 395		9.4	40.5	8.8	103.0
	510, 570, 620, 660, 690	445, 485, 505		12.6	45.5	12.5	115.0
YCAS	Air Entering Condenser	Standard Fans		°C		-3.9	45 *
		Slow Speed Fans		°C		.3.9	45 *
		Low Ambient Kit		°C		-18	45 *
	Fan Available External Static Pressure	Standard Fans		Pa		-	20
		Slow Speed Fans		Pa		-	10
		High Pressure Fans		Pa		-	100
Electrical Three Phase 50 Hz				volts		342	440

* Units operating above 45°C require sunshield over the control panels.

REFRIGERANT FLOW DIAGRAM

FIGURE 1

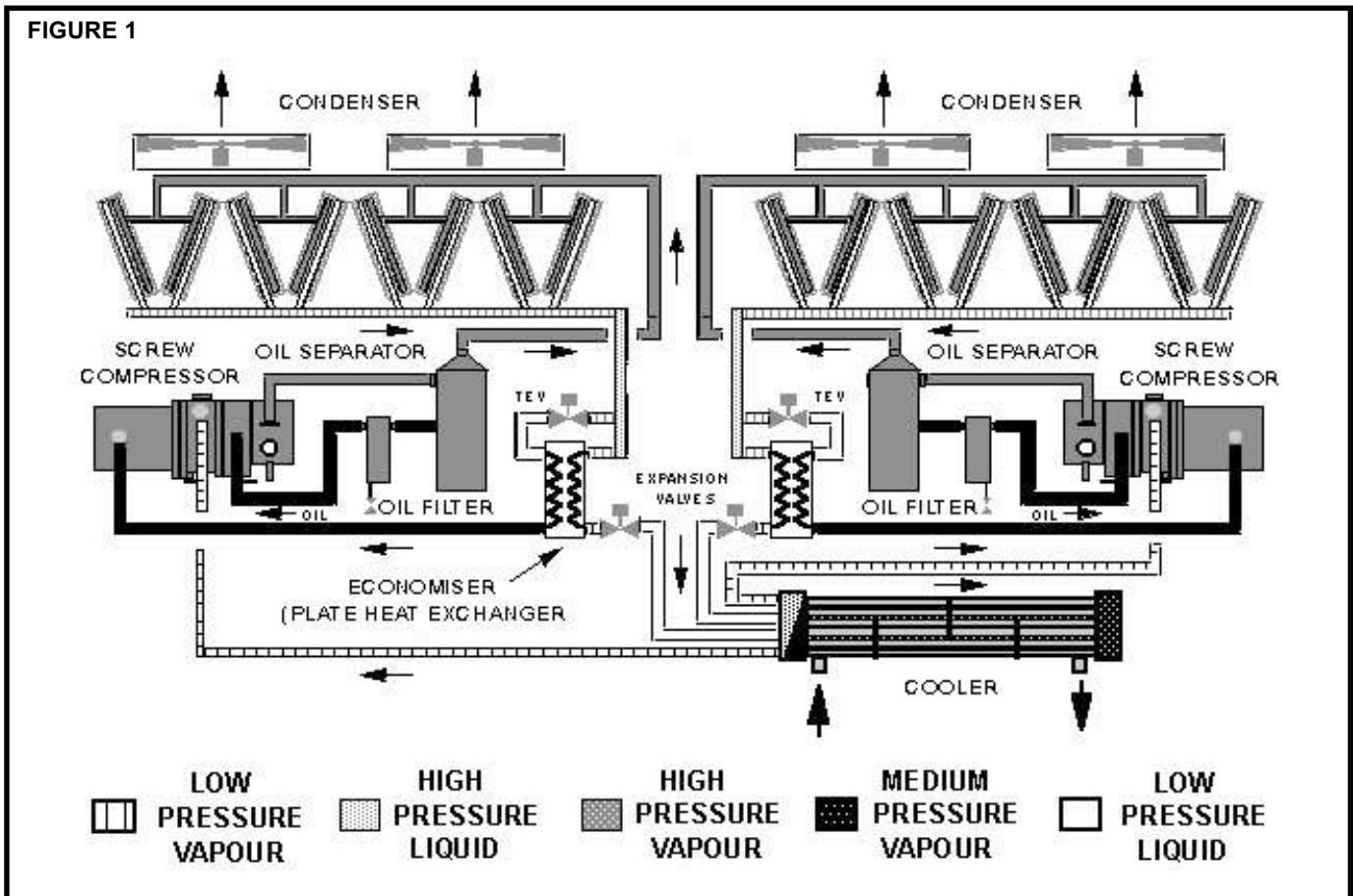

Low pressure liquid refrigerant enters the cooler and is evaporated and superheated by the heat energy absorbed from the chilled water passing through the cooler shell. Low pressure vapour enters the compressor where pressure and superheat are increased. Heat is rejected via the air cooled condenser coil and fans. The fully condensed liquid refrigerant enters the economiser. A small percentage of the liquid passes through an expansion valve, into the other side of the economiser, where it is evaporated. This low pressure liquid subcools the major part of the refrigerant. Medium pressure vapour then returns to the compressor. The subcooled refrigerant then passes through the expansion valve where pressure is reduced and further cooling takes place before returning to the cooler.

SELECTION GUIDE

DATA REQUIRED

To select a YORK YCAS chiller the following information is required:

1. Required cooling capacity.
2. Required refrigerant.
3. Design chilled water entering and leaving temperatures.
4. Design water flow rate if one of the temperatures in item 3 are unknown.
5. Design condenser entering air temperature. This will normally be the design summer ambient air temperature unless location or other factors have an influence.
6. Altitude above sea level.
7. Design cooler fouling factor.
8. Static pressure resistance against condenser entering and leaving air flow (where ducts, louvres, attenuators, etc., are used) at full unit air volume.

Note: Items 1, 3 and 4 must be linked by the following formulae:
 Cooling Capacity (kW) = Range (°C) x Flow (litre/sec) x 4.18
 Where Range = Entering liquid temperature - Leaving liquid temperature.

CHILLER SELECTION METHOD

1. Determine the correct size of chiller by selecting the model which most closely matches the required capacity at the design conditions of leaving water temperature and entering air temperature.
2. Apply correction factors for fouling factor (table 3) and altitude & fan application (tables 4 & 5) to the capacity and power values from the capacity tables. Ensure the corrected capacity is still sufficient for requirements.
3. Using the corrected capacity of the selected chiller adjust the design temperature range, or flow rate, to balance the formulae shown in "Data Required".
4. Physical and electrical data can now be determined from tables 8 to 10.
5. Always re-check that selections fall within the design limitations specified in table 2.

Table 3 FOULING FACTORS

COOLER		
Fouling factor m°C/kW	Capacity Factor	Comp. Input Factor
0.044	1.000	1.000
0.088	0.987	0.995
0.176	0.964	0.985
0.352	0.915	0.962

Table 4 ALTITUDE FACTORS

Altitude (m)	Capacity Factor	Comp. Input Factor
0	1.000	1.000
600	0.987	1.010
1200	0.973	1.020
1800	0.958	1.029
2400	0.943	1.038

Table 5 FAN APPLICATION FACTORS

Fan Type	External Static Pa	Capacity Factor	Comp. Input Factor
Slow Speed Fans	0	1.00	1.00
	10	0.99	1.01
Standard Fans	0	1.00	1.00
	20	0.99	1.01
High Head Fans	100	1.00	1.00

COOLING ONLY CHILLER SAMPLE SELECTION

An R22 chiller is required to cool water from 12°C to 7°C having a cooling capacity of 675kW at a design flow rate of 32.3 l/s. Other design conditions applying are:

Ambient air entering condenser	:32°C
Fouling Factor	:0.044m ² °C./kW
Altitude	:Sea level
Condenser air restriction	:None

From a cursory examination of capacity table 6, a model YCAS 620 gives approximately the required capacity:

Interpolating for 7°C water and 32°C air	
Capacity	=680.5 kW
Compressor Power	=190.8 kW

No correction factors apply therefore, after calculating the flow rate, the conditions will be as follows:

Cooling Capacity	:680.5 kW
Water temperature	:12°C to 7°C (Range = 5°C)
Water flow rate	:32.6 l/s
Compressor Power	:190.8 kW

All values are within the operating limits in table 2.

From Pressure Drop Graph (figure 2), using line B. YCAS 620 cooler water pressure drop = 64kPa at the calculated flow of 32.6l/s.

FIGURE 2 COOLER WATER PRESSURE DROPS

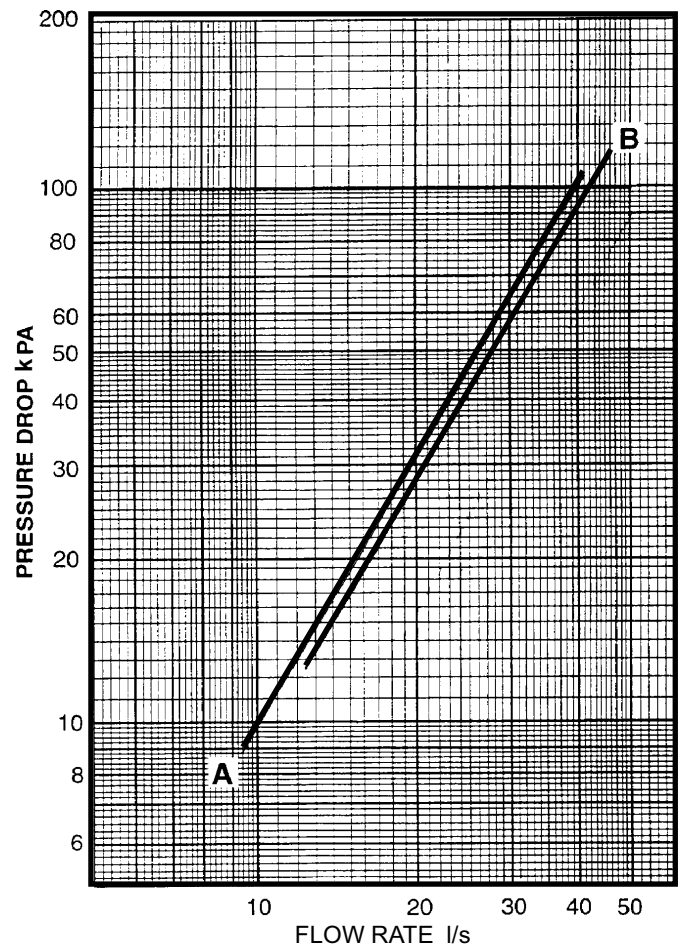

R22 YCAS	LINE	R134a YCAS	LINE
410, 430, 480	A	335, 355, 375, 395	A
510, 570, 620, 660, 690	B	445, 485, 505	B

Table 6

R22 - YCAS COOLING CAPACITIES

Model	LWT °C	Condenser Entering Air Temperature °C													
		20		25		30		35		40		45		50	
		Cool kW	Power kW	Cool kW	Power kW	Cool kW	Power kW	Cool kW	Power kW	Cool kW	Power kW	Cool kW	Power kW	Cool kW	Power kW
YCAS 410	4.5	440	71	431	84	421	98	413	113	880	130	393	149		
	6	459	72	448	84	439	99	431	114	421	131	411	151		
	8	484	72	474	86	464	100	456	116	445	133	435	153		
	10	510	73	500	87	490	101	481	117	470	135	459	155		
	12	537	73	590	88	517	103	507	119	497	137	484	157		
YCAS 430	4.5	468	80	457	93	445	108	434	124	422	145	408	168		
	6	488	80	477	94	465	109	454	126	441	147	426	170		
	8	516	81	502	95	490	111	479	129	466	149	450	173		
	10	542	81	529	96	518	113	505	131	491	151	476	176		
	12	570	82	539	98	546	114	533	133	519	154	501	179		
YCAS 480	4.5	523	96	508	112	494	129	480	149	463	173	443	203		
	6	544	96	529	113	515	131	501	152	484	176	464	206		
	8	573	98	559	115	544	133	528	154	510	180				
	10	603	99	588	117	573	136	557	157	539	183				
	12	634	100	618	118	603	138	586	160	566	187				
YCAS 510	4.5	562	105	547	122	531	141	516	163	498	189	477	221		
	6	586	106	570	124	554	143	539	166	520	192	498	224		
	8	618	107	603	126	586	146	569	169	549	196				
	10	651	109	634	128	618	149	600	172	579	200				
	12	686	111	669	130	652	152	632	176	610	204				
YCAS 570	4.5	620	121	603	140	586	162	568	186	548	215	524	249		
	6	646	123	629	143	612	164	593	188	572	219	547	254		
	8	680	125	664	145	646	168	626	194	604	224	576	259		
	10	716	127	698	148	680	171	659	198	636	229	607	265		
	12	755	129	736	151	717	175	695	203	670	234	639	272		
YCAS 620	4.5	678	131	659	152	642	176	623	202	602	231	576	266	545	307
	6	708	132	688	155	670	178	650	205	628	235	602	270	569	312
	8	746	134	727	157	707	182	687	209	663	240	634	276	600	319
	10	784	136	764	160	744	186	723	214	698	245	668	283		
	12	828	139	805	163	784	189	761	218	735	251	704	289		
YCAS 660	4.5	729	149	709	174	690	199	669	228	647	260	617	297	584	341
	6	760	151	740	176	719	203	698	232	674	265	645	303	608	347
	8	801	154	780	180	759	207	737	237	711	271	679	310	641	356
	10	842	159	821	183	799	212	776	243	749	278	715	318		
	12	886	160	865	187	842	216	817	248	788	284	752	325		
YCAS 690	4.5	755	161	735	186	716	213	694	242	670	275	641	311	603	354
	6	789	163	768	189	747	217	725	247	698	280	667	317		
	8	831	166	809	193	788	222	763	252	736	287	702	325		
	10	873	196	852	197	828	227	803	258	775	293	739	333		
	12	919	173	896	202	873	232	846	264	815	300	776	341		

LWT = Leaving Chilled Water Temperature
Power input is for compressors only

Table 7

R134a - YCAS COOLING CAPACITIES

Model	LWT °C	Condenser Entering Air Temperature °C													
		20		25		30		35		40		45		50	
		Cool kW	Power kW	Cool kW	Power kW	Cool kW	Power kW	Cool kW	Power kW	Cool kW	Power kW	Cool kW	Power kW	Cool kW	Power kW
YCAS 335	4.5	362	56	355	65	348	74	337	85	326	98	311	112	295	129
	6	379	57	373	66	365	75	355	87	343	99	329	114		
	8	404	57	397	67	390	77	379	89	368	101	353	116		
	10	429	58	423	68	415	78	405	91	392	103	378	119		
	12	457	59	450	69	442	80	432	92	418	106	401	120		
YCAS 355	4.5	380	60	373	70	364	80	353	93	342	106	328	121	310	139
	6	399	61	393	70	384	81	372	94	361	107	347	123	328	141
	8	426	61	418	71	410	83	399	96	386	109	372	125	353	144
	10	452	62	445	72	437	84	426	98	412	112	397	128	378	147
	12	479	63	473	74	464	86	454	100	439	114	422	131	403	150
YCAS 375	4.5	402	65	393	75	383	87	372	100	359	114	343	130	326	149
	6	422	66	414	77	404	88	392	102	379	116	363	132		
	8	450	67	441	78	432	90	420	104	406	119	390	135		
	10	479	67	469	80	460	92	448	106	433	121	417	138		
	12	822	68	499	41	488	94	477	109	461	124	444	142		
YCAS 395	4.5	423	70	413	82	402	94	390	108	377	123	360	139	340	158
	6	46	71	435	83	424	95	413	110	397	125	380	142		
	8	475	72	464	85	469	98	441	112	426	128	407	145		
	10	506	73	494	87	483	100	470	115	454	131	437	149		
	12	536	74	525	89	512	102	500	117	483	134	464	152		
YCAS 445	4.5	480	82	470	95	459	110	454	125	426	142	406	160		
	6	506	83	496	97	484	112	469	127	450	144	431	163		
	8	541	85	530	99	518	114	502	131	484	148	461	167		
	10	575	87	565	102	558	117	536	134	516	152				
	12	611	89	600	104	586	120	569	137	549	155				
YCAS 485	4.5	520	93	509	108	496	124	479	141	460	159	439	178		
	6	548	94	536	110	523	126	506	144	485	162	464	182		
	8	584	97	573	113	559	130	542	147	521	167	496	186		
	10	622	99	609	116	596	133	578	151	554	170				
	12	659	102	647	119	632	137	613	155	590	175				
YCAS 505	4.5	541	99	529	116	521	133	499	149	479	168	454	187	426	207
	6	574	101	558	118	548	136	526	153	505	172	479	192	450	213
	8	608	104	595	121	584	139	563	157	541	176	513	198	483	220
	10	646	106	633	124	620	143	600	161	575	181	547	203		
	12	685	109	672	127	656	146	636	165	611	185	582	209		

LWT = Leaving Chilled Water Temperature

Power input is for compressors only

Table 8

ELECTRICAL DATA (400 volts 3 phase 50Hz)

	ITEM	STANDARD FAN CHILLERS					HIGH			LOW		
		MAXIMUM RUNNING kW	MAXIMUM RUNNING kW				PRESSURE FAN ADDITIONS			NOISE FAN REDUCTIONS		
		1	2	3	4	5	6	7	8	9	10	11
REFRIGERANT	Unit Size	YCAS Total Unit	Single Electrical Input	YCAS system 1	YCAS system 2	Star Delta Starting	Total Unit kW	Single Electrical Input Amps	Amps per system	Total Unit kW	Single Electrical input	Amps per system
R 134 a	335	157	276	147	129	184	8	11	5.5	3	6	3
	355	168	294	147	147	184	8	11	5.5	6	3	3
	375	173	302	155	147	184	8	11	5.5	3	6	3
	395	178	309	155	155	184	8	11	5.5	3	6	3
	445	193	334	180	155	220	8	11	5.5	3	6	3
	485	209	359	180	180	220	1	1	0.5	3	15	7.5
	505	242	415	208	208	265	1	1	0.5	3	15	7.5
R 22	410	198	342	171	171	184	8	11	5.5	3	6	3
	430	235	404	233	171	265	8	11	5.5	3	6	3
	480	272	466	233	233	265	8	11	5.5	3	6	4
	510	272	466	233	233	265	8	11	5.5	3	15	7.5
	570	308	528	264	264	332	1	1	0.5	3	15	7.5
	620	341	559	326	264	410	1	0.5	0.5	3	15	7.5
	660	374	652	326	326	410	1	1	0.5	3	15	7.5
	690	374	652	326	326	410	15	22	11	6	12	6

ELECTRICAL CONNECTIONS

Standard Units and Units with Isolators

All units require two off 3 phase separately fused 3 wire supplies plus earth. One supply should be connected to each of the two power supply sections in the control panel.

Also required is a separate supply, connected to customer terminals in the centre common power section of the control panel. This supply is for the control system and should be 220/230V single phase on 4 wire units or optionally two phases (380/400V) on units fitted with a 3 wire supply kit.

Units with Common Input Supply

Units fitted with common supply input accessory require only one 3 phase 4 wire supply plus earth, per control panel, or optionally one 3 phase 3 wire supply plus earth on units fitted with a 3 wire supply kit.

ALL SOURCES OF SUPPLY TO THE UNIT MUST BE TAKEN FROM ONE MAIN ISOLATOR NOT SUPPLIED BY YORK

Power Section Volt Free Contacts

All wiring to the power section voltage free contacts require a supply provided by the customer maximum voltage 240 volts. The customer MUST take particular care deriving the supplies for the voltage free terminals with regard to a common point of isolation. Thus, these circuits when used MUST be fed via the common point of isolation so the voltage to these circuits is removed when the common point of isolation to the unit is opened. This common point of isolation is not supplied by York. The York voltage free contacts are rated at 125VA.

All inductive devices (relays) switch by the York voltage free contacts must have their coil suppressed using standard R/C suppressors.

LOGIC SECTION

All wiring to the logic section terminal block is nominal 30Vdc and must be run in screened cable, with the screen earthed at panel end only. Run screen cable separately from mains cable to avoid electrical noise pick-up. Use gland plate on the back of the control panel directly into the logic section to avoid mains cables. If the cable exceeds 7.5 metres use the Micropanel Isolator Kit accessory. *Note: This accessory uses 15Vdc not 30 Vdc.* The voltage free contacts must be suitable for 24Vdc (gold contact recommended). If voltage free contact forms part of a relay or contactors, the coil of this device MUST be suppressed by using a standard R/C suppressor. The above precautions MUST be taken to avoid electrical noise which could cause a malfunction or damage to the units and its controls.

TOTAL UNIT KW (ITEM 1)

If High Pressure Fans are included, instead of Standard Fan, add data from item 6. If Low Noise Fans are included, deduct data from item 9. Total maximum kW is at 6°C leaving chilled water and 45°C ambient. For maximum kW at 6°C leaving chilled water and 35°C ambient multiply the result by 0.83.

SINGLE ELECTRICAL CONNECTION AMPS (ITEM 2).

This accessory option is a single electrical connection on YCAS units, rather than the standard two inputs for each of the compressor/ fan systems. If high pressure or low noise fans are included, add or deduct, as appropriate, data from items 7 or 10.

Use the resulting data to size electrical cables per panel.

SYSTEM ELECTRICAL INPUTS (ITEMS 3 & 4)

For standard chillers, where item 2 is not included, YCAS chillers will have one input from each of items 3 and 4.

If High Pressure or Low Noise Fans are included add or deduct, as appropriate, data from items 8 or 11 to each compressor/ fan system.

Use the resulting data to size electrical cables per system

STARTING AMPS (ITEM 5)

Starting amps are for the largest compressor.

All currents are at nominal 400 volts. For 380 volt supplies (outside Europe), multiply amps by 1.05.

Table 9

PHYSICAL DATA YCAS R22

REFRIGERANT			R22							
MODEL	YCAS		410	430	480	510	570	620	660	690
Number of Refrigerant Circuits			2	2	2	2	2	2	2	2
COMPRESSOR	System No. 1	XHS120	BA50G	BM50L	BF50L	BF50L	CH50N	CP50Q	CP50Q	CS50Q
	System No. 2	XHS120	BA50G	BA50G	BM50L	BF50L	CH50N	CH50N	CP50Q	CS50Q
	Total Oil capacity litres		15	15	15	15	15	15	15	15
COOLER (Quantity 1)	Model of Cooler DXC		1608	1608	1608	1808	1808	1808	1808	1808
	Number of circuits		2	2	2	2	2	2	2	2
	Water Capacity litres		150	150	150	177	177	177	177	177
CONDENSER	Number of Condenser Modules		2	2	2	2	2	2	2	2
	Face Area m ²		27.4	27.4	27.4	27.4	27.4	27.4	27.4	27.4
	Number of tube rows		3	3	3	3	3	4	4	4
FANS	Quantity		8	8	8	8	8	8	8	8
	Standard 950rpm	kW	2.2	2.2	2.2	2.2	2.2	2.2	2.2	2.2
		Total Airflow m ³ /s	58.2	58.2	58.2	58.2	58.2	56.2	56.2	56.2
		Ext. Stat Press. Pa	20	20	20	20	20	20	20	20
	Low Noise 730rpm	kW	2.2	2.2	2.2	2.2	2.2	2.2	2.2	2.2
		Total Airflow m ³ /s	58.2	58.2	58.2	58.2	58.2	58.2	58.2	58.2
		Ext. Stat Press. Pa	5	5	5	5	5	5	5	5
	High Head 950rpm	kW	4.1	4.1	4.1	4.1	4.1	4.1	4.1	4.1
		Total Airflow m ³ /s	58.2	58.2	58.2	58.2	58.2	58.2	58.2	58.2
Ext. Stat Press. Pa		100	100	100	100	100	100	100	100	
WEIGHT	Aluminum Fins	Shipping kg	6990	6990	6990	7370	7370	7524	7524	7524
		Operating kg	7140	7140	7140	7547	7547	7700	7700	7700
	Copper Fins	Shipping kg	8080	8080	8080	8460	8460	8974	8974	8974
		Operating kg	8230	8230	8230	8637	8637	9150	9150	9150

Table 10

PHYSICAL DATA YCAS R134a

REFRIGERANT			R134a						
MODEL	YCAS		335	355	375	395	445	485	505
Number of Refrigerant Circuits			2	2	2	2	2	2	2
COMPRESSOR	System No. 1	XHS120	BF50G	BF50G	BH50G	BH50G	BP50J	BP50J	BS50L
	System No. 2	XHS120	BM59E	BF50G	BF50G	BH50G	BH50G	BP50J	BS50L
	Total Oil capacity litres		15	15	15	15	15	15	15
COOLER (Quantity 1)	Model of Cooler DXC		1608	1608	1608	1608	1808	1808	1808
	Number of circuits		2	2	2	2	2	2	2
	Water Capacity litres		150	150	150	150	177	177	177
CONDENSER	Number of Condenser Modules		2	2	2	2	2	2	2
	Face Area m ²		27.4	27.4	27.4	27.4	27.4	27.4	27.4
	Number of tube rows		3	3	3	3	3	3	3
FANS	Quantity		8	8	8	8	8	8	8
	Standard 950rpm	kW	2.2	2.2	2.2	2.2	2.2	2.2	2.2
		Total Airflow m ³ /s	58.2	58.2	58.2	58.2	58.2	58.2	58.2
		Ext. Stat Press. Pa	20	20	20	20	20	20	20
	Low Noise 730rpm	kW	2.2	2.2	2.2	2.2	2.2	2.2	2.2
		Total Airflow m ³ /s	58.2	58.2	58.2	58.2	58.2	58.2	58.2
		Ext. Stat Press. Pa	5.0	5.0	5.0	5.0	5.0	5.0	5.0
	High Head 950rpm	kW	4.1	4.1	4.1	4.1	4.1	4.1	4.1
		Total Airflow m ³ /s	58.2	58.2	58.2	58.2	58.2	58.2	58.2
Ext. Stat Press. Pa		100	100	100	100	100	100	100	
WEIGHT	Aluminum Fins	Shipping kg	6990	6990	6990	6990	7370	7370	7370
		Operating kg	7140	7140	7140	7140	7547	7547	7547
	Copper Fins	Shipping kg	8080	8080	8080	8080	8460	8460	8460
		Operating kg	8230	8230	8230	8230	8637	8637	8637

ELECTRICAL CONNECTIONS

Standard Unit Supply Control Panel

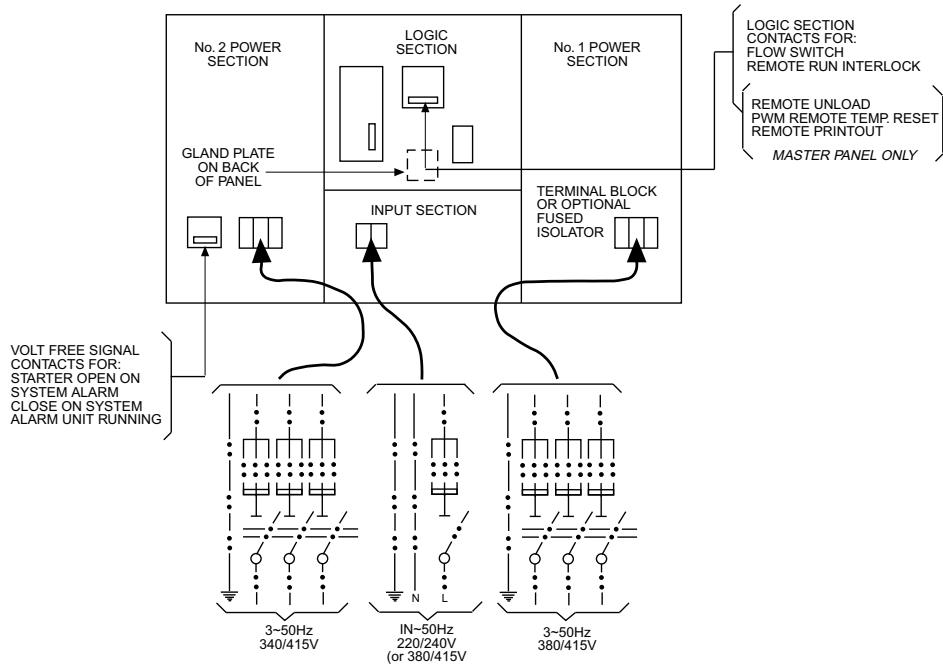

CONTROL PANEL FOR YCAS CHILLERS

POWER SECTION

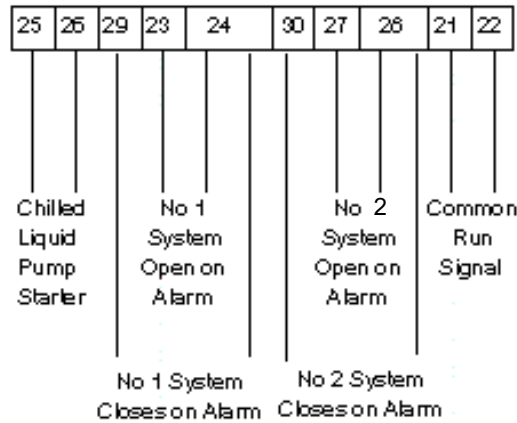

LOGIC SECTION

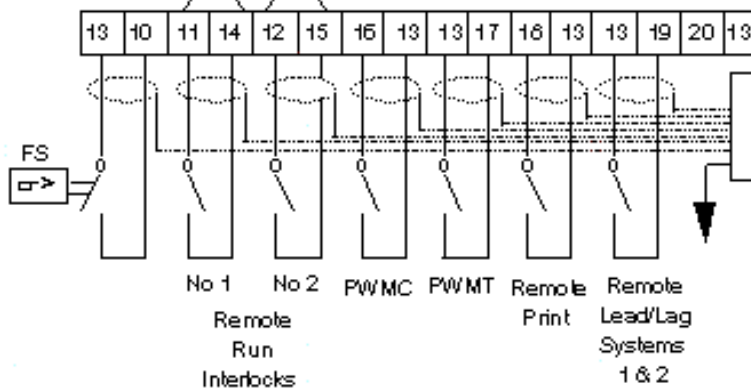

PWMC = Pulse Width Modulator/urrent
 PWMT = Pulse width Modulator/temperature

ALL DIMENSIONS IN MILLIMETRES

- The minimum required clearances to prevent condenser air re-circulation and faulty operations of units are as follows:
 Side to wall 2.5m
 Rear to wall 1.5m
 Front to wall 1.5m
 Distance between adjacent units 3.7m
 Minimum distance between the top of the unit and a horizontally projecting obstruction 15m
 The area within the clearances shown and below the unit must be kept clear of all obstructions that would impede free airflow to the unit.
 In installations where winter operation is intended, and snow accumulations are expected, additional unit height must be provided to ensure full airflow.
 Vibration isolators (not shown) will increase the overall height of the Chiller by approximately 178mm.
- Water inlet and outlet connections are for Victaulic couplings for optional ISO flanges.
- AVM = ANTI VIBRATION MOUNT location.

COOLER CONNECTIONS

B = WATER OUTLET 8"NB
C = WATER INLET 8"NB

MODELS R134A	DIM A	MODELS R22	DIM A
YCAS 505	457	YCAS 520	457
YCAS 445	432	YCAS 570	432
YCAS 395		YCAS 430	
YCAS 325		YCAS 410	

